



# PIC16C712/716

## PIC16C712/716 Rev. A Silicon/Data Sheet Errata

The PIC16C712/716 parts you have received conform functionally to the Device Data Sheet (DS41106A), except for the anomalies described below.

The problem here will be addressed in future revisions of the PIC16C712/716 silicon.

### 1. Module: CCP

When using the PIC16C712/716 in the Compare or PWM mode, the TCCP bit of the TRISCCP register will not tristate the output on pin RB3, as described in Figure 7-2 of the Device Data Sheet. The TCCP bit of the TRISCCP register has no effect on the output of pin RB3.

**Note:** The TCCP bit of the TRISCCP register functions as described in Figure 7-2 of the Device Data Sheet, when using the MPLAB® ICE 2000 in-circuit emulator

### Work around

There is no way to tristate the output on pin RB3 in the Compare or PWM mode. However, there are steps you can do in firmware to stop the RB3 pin from changing and leave it in a known state. Examples are shown below.

### EXAMPLE 1:

(Assumes that the T2CON and CCP1CON values are determined at assembly time and remain fixed.)

### *Software License Agreement*

The software supplied herewith by Microchip Technology Incorporated (the "Company") is intended and supplied to you, the Company's customer, for use solely and exclusively with products manufactured by the Company.

The software is owned by the Company and/or its supplier, and is protected under applicable copyright laws. All rights are reserved. Any use in violation of the foregoing restrictions may subject the user to criminal sanctions under applicable laws, as well as to civil liability for the breach of the terms and conditions of this license.

THIS SOFTWARE IS PROVIDED IN AN "AS IS" CONDITION. NO WARRANTIES, WHETHER EXPRESS, IMPLIED OR STATUTORY, INCLUDING, BUT NOT LIMITED TO, IMPLIED WARRANTIES OF MERCHANTABILITY AND FITNESS FOR A PARTICULAR PURPOSE APPLY TO THIS SOFTWARE. THE COMPANY SHALL NOT, IN ANY CIRCUMSTANCES, BE LIABLE FOR SPECIAL, INCIDENTAL OR CONSEQUENTIAL DAMAGES, FOR ANY REASON WHATSOEVER.

### Code Example 1A:

```
*****
; Call these routines to turn the PWM off or on and ensure a Zero output on RB3
; when PWM is off.
;
; PWMreset - Clear T2CON Disabling Timer2 and Clearing Timer 2 Prescaler,
;           then fill the TMR2 register with the CCPR1H value. This will cause
;           a Reset or Zero value on RB3.
;
; PWMrestart - Restore the T2CON register with the appropriate value for your
;             system needs. IT IS THE RESPONSIBILITY OF THE USER TO DETERMINE
;             THE CORRECT VALUE FOR T2CON.
```

### Assembly Code To Stop PWM Once Started:

```
PWMreset
    bcf     STATUS,RP0      ; Select Bank 0
    clrf   T2CON           ; Clear T2CON, Timer2-Disable & Pre/Post Scalers = 1
    movf   CCPR1H,W        ; Load CCPR1H value in Write register
    movwf  TMR2            ; Move CCPR1H value into TMR2 to cause Reset of RB3 pin
    return
```

# PIC16C712/716

---

## Assembly Code To Start PWM Once Stopped:

```
PWMrestart
    bcf     STATUS,RP0      ; Select Bank 0
    movlw  T2CONVAL        ; Load T2CON value in 'w' register - USER RESPONSIBLE FOR
                          ; SUPPLYING THE CORRECT T2CON VALUE.
    movwf  T2CON           ; Initialize T2CON enabling scalers and Timer2
    return
```

## **Code Example 1B:**

```
;*****
; Call these routines to turn the CCP Mode off or on and ensure RB3 is a known
; Input or Output value when CCP Mode is off.
;
;
; CCPstop - First sets RB3 to an Input or an Output. If RB3 is an Output then it's state is made
; either High or Low. The CCP is then Disabled.
;
; CCPstart - Enable CCP Mode. IT IS THE RESPONSIBILITY OF THE USER TO DETERMINE THE CORRECT
; VALUE FOR CCP1CON.
```

## Assembly Code To Stop CCP Mode Once Started:

```
CCPstop
    bsf     STATUS,RP0      ; Select Bank 1
    bcf     TRISB,3         ; RB3 as an Output - set bit TRISB, 3 when RB3
                          ; as an Input is desired.
    bcf     STATUS,RP0      ; Select Bank 0
    bcf     PORTB,3         ; RB3 as a Low Level Output - Set bit TRISB,3 for
                          ; RB3 to be a High Level
                          ; Output.
    movlw  0x30             ; Load CCP1CON value in Working register
    movwf  CCP1CON         ; Turn Off CCP1CON all Modes
    return
```

## Assembly Code To Start CCP Mode Once Stopped:

```
CCPstart
    bcf     STATUS,RP0      ; Select Bank 0
    movlw  CCP1CONVAL       ; Load CCP1CON value in Working register.
                          ; THE USER IS RESPONSIBLE FOR SUPPLYING THE CORRECT CCP1CON VALUE.
    movwf  CCP1CON         ; Initialize CCP1CON for desired Mode of operation.
    return
```

## EXAMPLE 2:

(Assumes that the T2CON and CCP1CON values may change during program execution. One SRAM location is used for temporary storage of T2CON or CCP2CON.)

### Code Example 2A:

```
;*****  
; Call these routines to turn the PWM off or on and ensure a Zero output on RB3  
; when PWM is off.  
;  
; PWMreset - Saves T2CON value in RAM location. IT IS THE RESPONSIBILITY OF THE USER TO SUPPLY  
; RAM MEMORY SPACE TO SAVE THE T2CON VALUE.  
; Clears T2CON register Disabling Timer2 and clearing Timer2 Prescaler.  
; The TMR2 register is then filled with the CCP1H value. This causes a Reset  
; or Zero value on RB3.  
;  
;  
; PWMrestart - Enable Timer2
```

### Assembly Code To Stop PWM Once Started:

```
T2CONSAV equ 0x?? ; USER RESPONSIBLE FOR SUPPLYING RAM MEMORY SPACE  
; TO SAVE T2CON VALUE.  
  
PWMreset  
    bcf     STATUS,RP0 ; Select Bank 0  
    movf   T2CON,W     ; Move T2CON Value to 'w' register  
    movwf  T2CONSAV    ; Save T2CON register value  
    clrf   T2CON       ; Clear T2CON, Timer2-Disable & Pre/Post Scalers=1  
    movf   CCP1H,W     ; Load CCP1H value in Write register  
    movwf  TMR2        ; Move CCP1H value into TMR2 to cause Reset of RB3 pin  
    return
```

### Assembly Code To Start PWM Once Stopped:

```
PWMrestart  
    bcf     STATUS,RP0 ; Select Bank 0  
    movf   T2CONSAV,W  ; Move T2CONSAV Value to 'w' register  
    movwf  T2CON       ; Restore T2CON register value  
    return
```

# PIC16C712/716

---

## Code Example 2B:

```
;*****  
; Call these routines to turn the CCP Mode off or on and ensure RB3 is a known  
; Input or Output value when CCP Mode is off.  
;  
; CCPstop - First sets RB3 to an Input or an Output. If RB3 is an Output then it's state  
; is made either High or Low. The CCP is then Disabled.  
;  
; CCPstart - Enable CCP Mode. IT IS THE RESPONSIBILITY OF THE USER TO DETERMINE THE CORRECT  
; VALUE FOR CCP1CON.
```

## Assembly Code To Stop CCP Mode Once Started:

```
CCP1CONSAV equ 0X??          ; USER IS RESPONSIBLE FOR SUPPLYING RAM MEMORY SPACE  
                               ; TO SAVE CCP2CON VALUE.  
CCPstop  
    bsf     STATUS,RP0        ; Select Bank 1  
    bcf     TRISB,3           ; RB3 as an Output - set bit TRISB, 3 when RB3  
                               ; as an Input is desired.  
    bcf     STATUS,RP0        ; Select Bank 0  
    bcf     PORTB,3           ; RB3 as a Low Level Output - set bit PORTB,3  
                               ; for RB3 to be a High Level  
                               ; Output.  
    movf    CCP1CON,W         ; Move CCP1CON to 'W' register  
    movwf   CCP1CONSAV        ; Save CCP1CON register value  
    movlw   0x30              ; Load CCP1CON value in Working register  
    movwf   CCP1CON           ; Turn Off CCP1CON all Modes  
    return
```

## Assembly Code To Start CCP Mode Once Stopped:

```
CCPstart  
    bcf     STATUS,RP0        ; Select Bank 0  
    movf    CCP1CONSAV,W      ; Move CCP1CONSAV value to 'W' register  
    movwf   CCP1CON           ; Restore CCP1CON to desired Mode of operation.  
    return
```

## 2. Module: Timer1

When Timer1 is configured to operate as an asynchronous counter, care must be taken that there is no incoming pulse while the module is being turned off. If an incoming pulse arrives while Timer1 is being turned off (i.e., TMR1ON transitions from 1 to 0), the value of registers TMR1L and TMR1H will be unpredictable.

### Work around

This solution involves changing Timer1 from Asynchronous to Synchronous mode before turning off Timer1. No additional resources are required for this solution.

Timer1 synchronization will start, effectively stopping Timer1, one Q period after the Synchronous mode is enabled, or one Q period later than would have been realized by simply clearing the TMR1ON bit. One additional count, in excess of the counts accrued during this extra Q period, may be accumulated before the TMR1ON bit is eventually cleared in the next instruction. The occurrence of this additional count is dependent on the phase relationship between OSC1, or the internal system clock, and T1CKI.

### Code Example:

```
*****
; Call this routine to stop Timer1 asynchronous counting
;
; Timer1 is stopped after the timer is changed to synchronous mode
; The captured timer value resides in TMR1H and TMR1L at the completion of this
; routine.

TMR1Capture                ; entry point
    bcf    T1CON,NOT_T1SYNC ; set for synchronous mode
    bcf    T1CON,TMR1ON     ; stop timer
    bsf    T1CON,NOT_T1SYNC ; restore asynchronous mode
    return                  ; return to calling routine
```

# PIC16C712/716

## Clarifications/Corrections to the Data Sheet:

In the Device Data Sheet (DS41106A), the following clarifications and corrections should be noted.

- The following register and bit names need the following corrections:

Page	Where	Occurrence	Data Sheet Name	Correct Name
10	Figure 2-3, Address 0Fh	1	TRM1H	TMR1H
10	Figure 2-3, Address 11h	1	TRM2	TMR2
41	Table 7-2, Address 07h, bit 0	1	TT1CK	DT1CK
44	Table 7-5, Control Bits column	4	TR1SCCP	TRISCCP

- Figure 3-4, page 24, of the Device Data Sheet should show the following block diagram for RB1/T1OSO/T1CKI:

**FIGURE 3-4: BLOCK DIAGRAM OF RB1/T1OSO/T1CKI PIN**

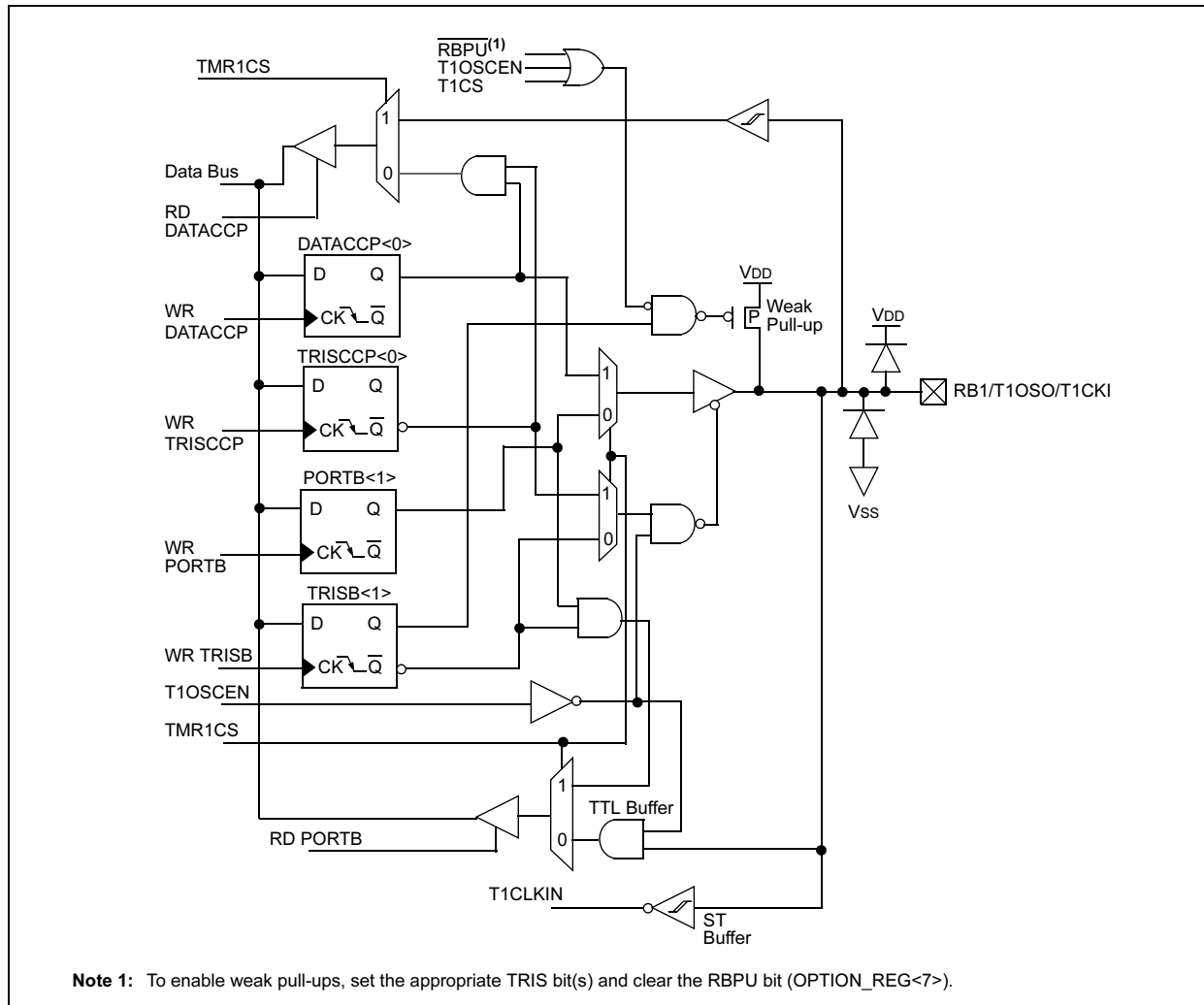

3. Figure 12-1, page 76, of the Device Data Sheet should show the following valid region of operation:

**FIGURE 12-5: PIC16C712/716 VOLTAGE-FREQUENCY GRAPH,  $-40^{\circ}\text{C} \leq T_A \leq +125^{\circ}\text{C}$**

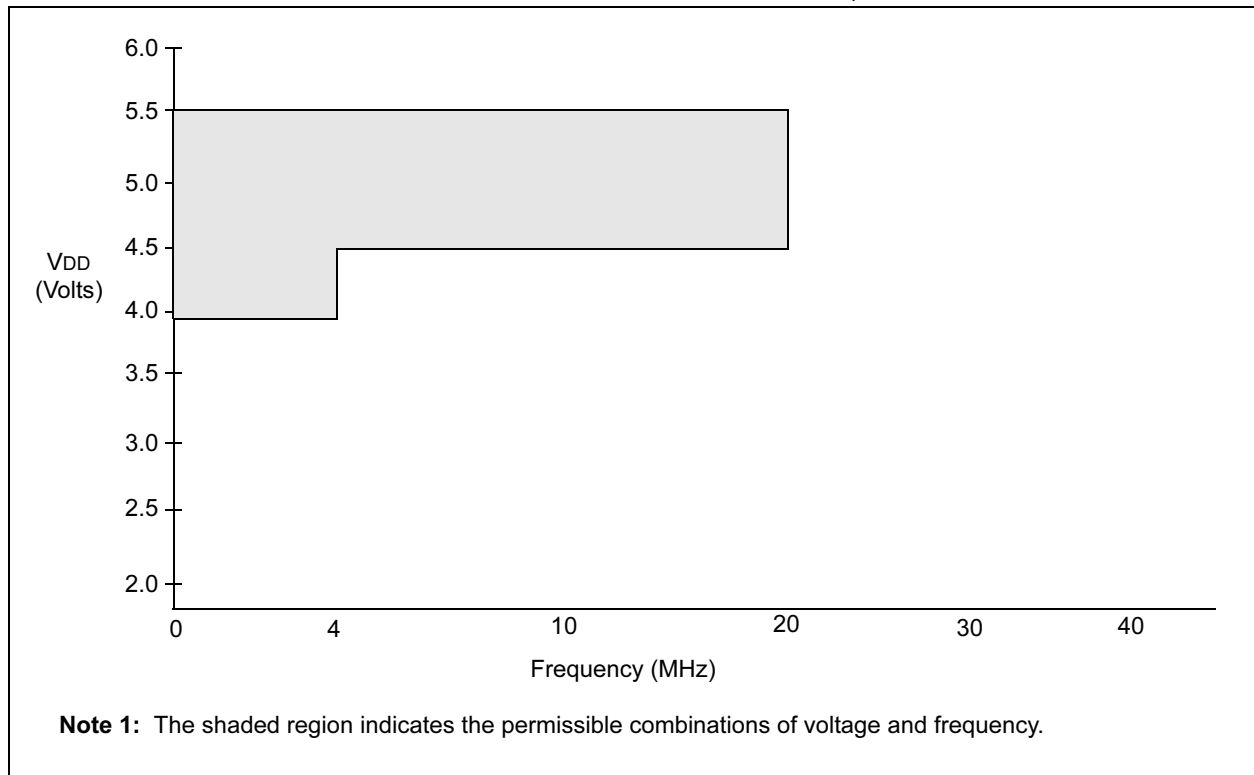

4. Parameter No. D001, page 77, of the Device Data Sheet should show the following values:

## 12.1 DC Characteristics: PIC16C712/716-04 (Commercial, Industrial, Extended) PIC16C712/716-20 (Commercial, Industrial, Extended)

DC CHARACTERISTICS		Standard Operating Conditions (unless otherwise stated)					
		Operating temperature					
		0°C ≤ T <sub>A</sub> ≤ +70°C for commercial					
		-40°C ≤ T <sub>A</sub> ≤ +85°C for industrial					
		-40°C ≤ T <sub>A</sub> ≤ +125°C for extended					
Param No.	Sym	Characteristic	Min	Typ†	Max	Units	Conditions
D001	V <sub>DD</sub>	Supply Voltage	4.0	—	5.5	V	XT, RC and LP osc mode
D001A			4.5	—	5.5	V	HS osc mode
			V <sub>BOR</sub> *	—	5.5	V	BOR enabled <sup>(7)</sup>

# PIC16C712/716

## 5. Module: Packaging

The package information contained in the data sheet is incorrect. Please refer to the following tables for correct package data.

### 18-Lead Plastic Dual In-line (P) – 300 mil (PDIP)

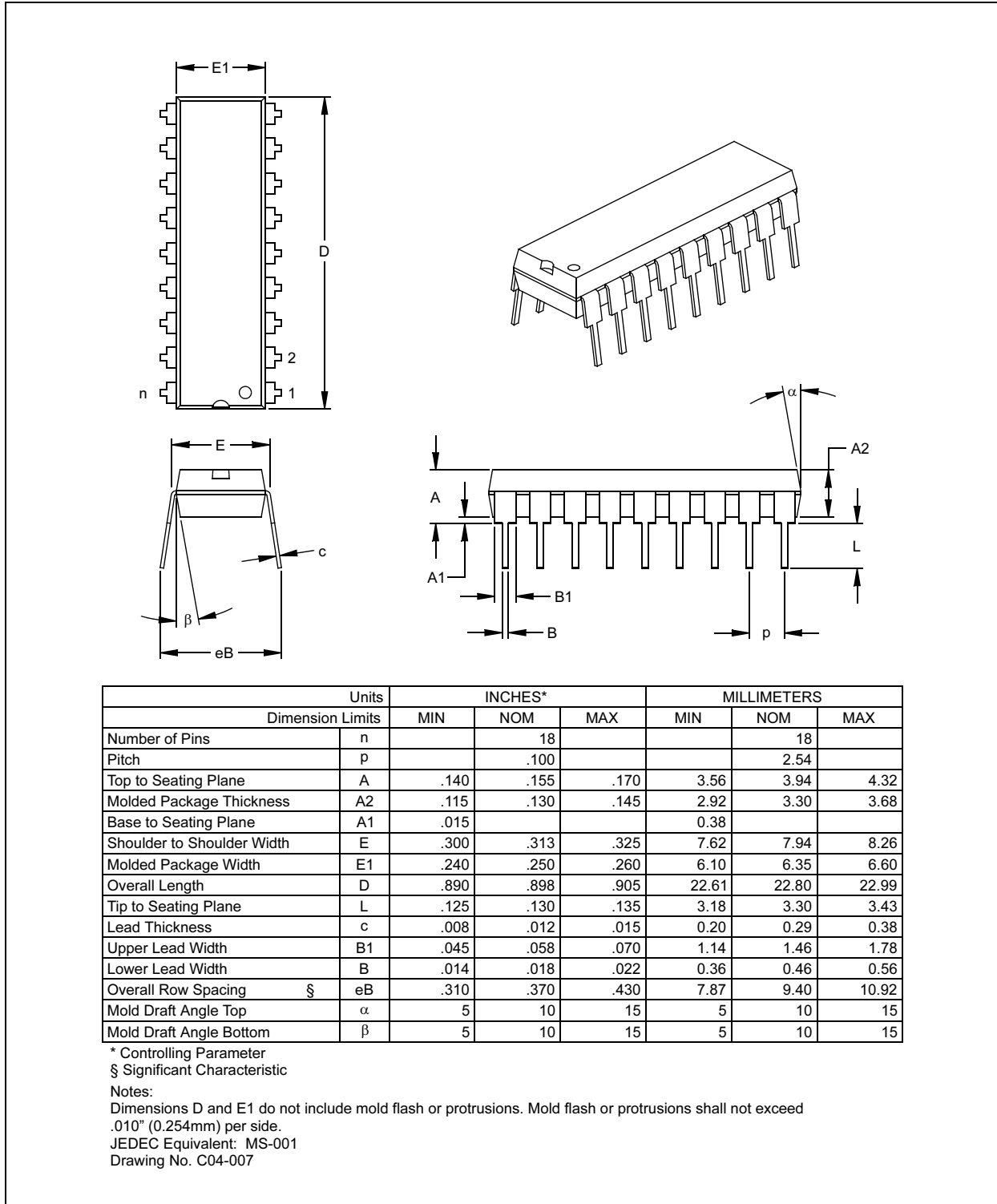



## 18-Lead Plastic Small Outline (SO) – Wide, 300 mil (SOIC)

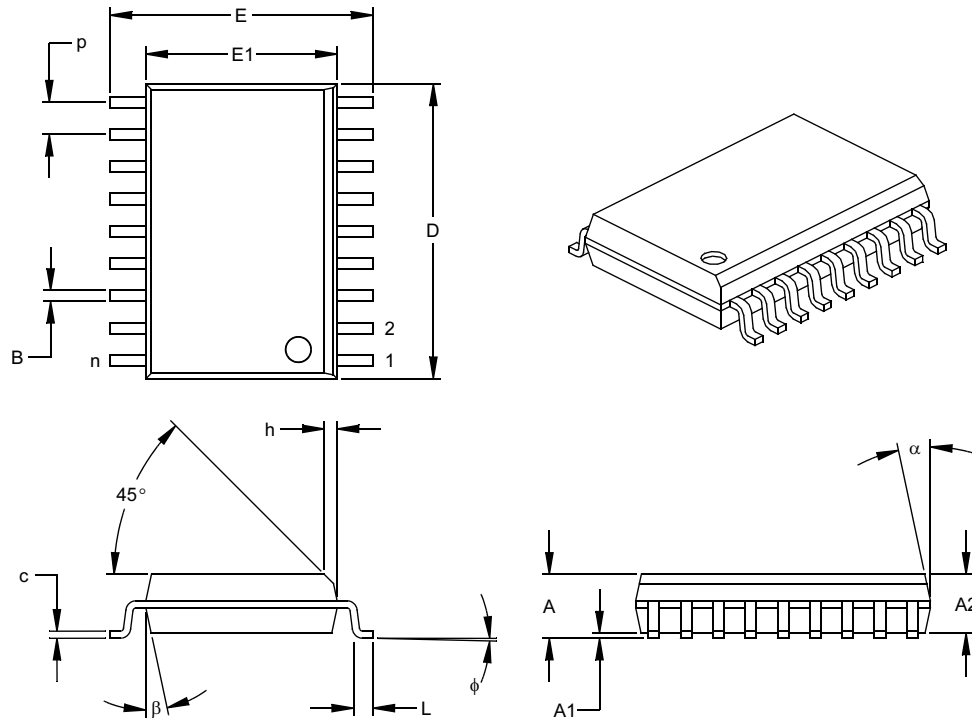

Units		INCHES*			MILLIMETERS		
Dimension	Limits	MIN	NOM	MAX	MIN	NOM	MAX
Number of Pins	n		18			18	
Pitch	p		.050			1.27	
Overall Height	A	.093	.099	.104	2.36	2.50	2.64
Molded Package Thickness	A2	.088	.091	.094	2.24	2.31	2.39
Standoff §	A1	.004	.008	.012	0.10	0.20	0.30
Overall Width	E	.394	.407	.420	10.01	10.34	10.67
Molded Package Width	E1	.291	.295	.299	7.39	7.49	7.59
Overall Length	D	.446	.454	.462	11.33	11.53	11.73
Chamfer Distance	h	.010	.020	.029	0.25	0.50	0.74
Foot Length	L	.016	.033	.050	0.41	0.84	1.27
Foot Angle	φ	0	4	8	0	4	8
Lead Thickness	c	.009	.011	.012	0.23	0.27	0.30
Lead Width	B	.014	.017	.020	0.36	0.42	0.51
Mold Draft Angle Top	α	0	12	15	0	12	15
Mold Draft Angle Bottom	β	0	12	15	0	12	15

\* Controlling Parameter  
 § Significant Characteristic

**Notes:**

Dimensions D and E1 do not include mold flash or protrusions. Mold flash or protrusions shall not exceed .010" (0.254mm) per side.

JEDEC Equivalent: MS-013

Drawing No. C04-051

# PIC16C712/716

## 18-Lead Ceramic Dual In-line with Window (JW) – 300 mil (CERDIP)

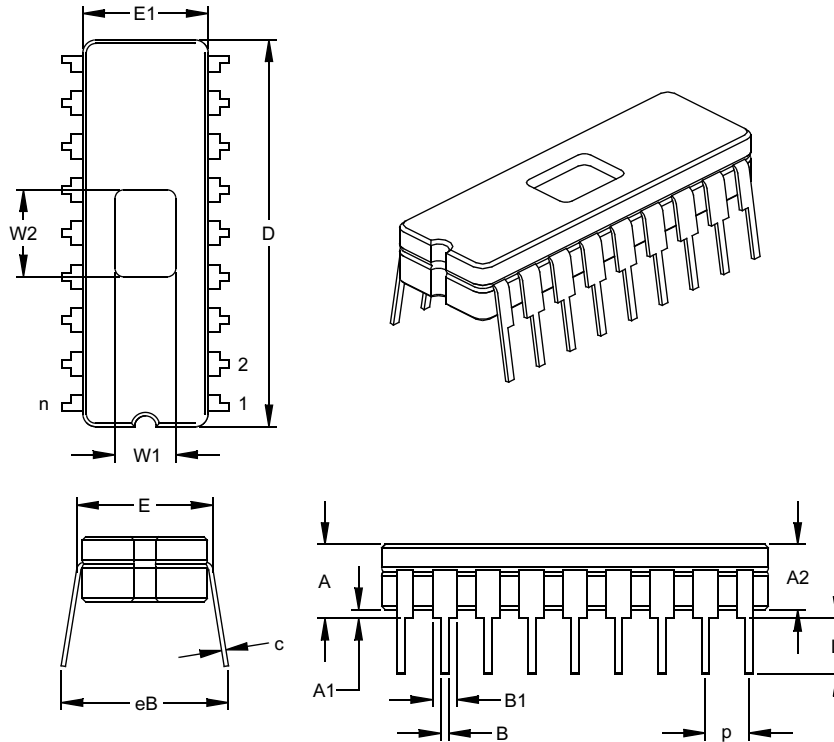

Dimension Limits	Units	INCHES*			MILLIMETERS		
		MIN	NOM	MAX	MIN	NOM	MAX
Number of Pins	n		18			18	
Pitch	p		.100			2.54	
Top to Seating Plane	A	.170	.183	.195	4.32	4.64	4.95
Ceramic Package Height	A2	.155	.160	.165	3.94	4.06	4.19
Standoff	A1	.015	.023	.030	0.38	0.57	0.76
Shoulder to Shoulder Width	E	.300	.313	.325	7.62	7.94	8.26
Ceramic Pkg. Width	E1	.285	.290	.295	7.24	7.37	7.49
Overall Length	D	.880	.900	.920	22.35	22.86	23.37
Tip to Seating Plane	L	.125	.138	.150	3.18	3.49	3.81
Lead Thickness	c	.008	.010	.012	0.20	0.25	0.30
Upper Lead Width	B1	.050	.055	.060	1.27	1.40	1.52
Lower Lead Width	B	.016	.019	.021	0.41	0.47	0.53
Overall Row Spacing	§ eB	.345	.385	.425	8.76	9.78	10.80
Window Width	W1	.130	.140	.150	3.30	3.56	3.81
Window Length	W2	.190	.200	.210	4.83	5.08	5.33

\* Controlling Parameter  
 § Significant Characteristic  
 JEDEC Equivalent: MO-036  
 Drawing No. C04-010

## 20-Lead Plastic Shrink Small Outline (SS) – 209 mil, 5.30 mm (SSOP)

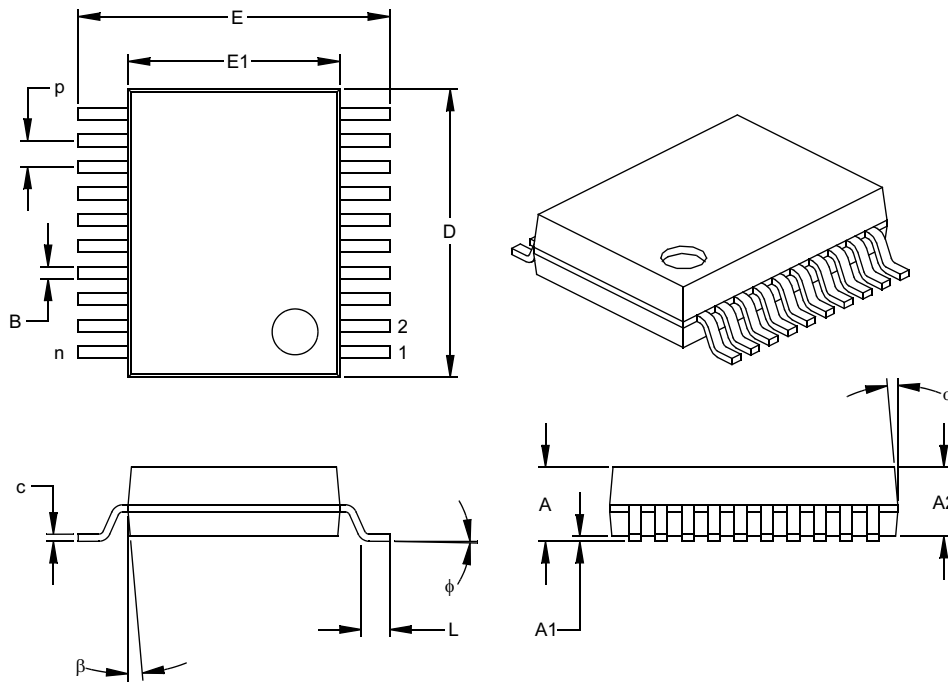

Units		INCHES*			MILLIMETERS		
Dimension Limits		MIN	NOM	MAX	MIN	NOM	MAX
Number of Pins	n		20			20	
Pitch	p		.026			0.65	
Overall Height	A	.068	.073	.078	1.73	1.85	1.98
Molded Package Thickness	A2	.064	.068	.072	1.63	1.73	1.83
Standoff §	A1	.002	.006	.010	0.05	0.15	0.25
Overall Width	E	.299	.309	.322	7.59	7.85	8.18
Molded Package Width	E1	.201	.207	.212	5.11	5.25	5.38
Overall Length	D	.278	.284	.289	7.06	7.20	7.34
Foot Length	L	.022	.030	.037	0.56	0.75	0.94
Lead Thickness	c	.004	.007	.010	0.10	0.18	0.25
Foot Angle	φ	0	4	8	0.00	101.60	203.20
Lead Width	B	.010	.013	.015	0.25	0.32	0.38
Mold Draft Angle Top	α	0	5	10	0	5	10
Mold Draft Angle Bottom	β	0	5	10	0	5	10

\* Controlling Parameter

§ Significant Characteristic

**Notes:**

Dimensions D and E1 do not include mold flash or protrusions. Mold flash or protrusions shall not exceed .010" (0.254mm) per side.

JEDEC Equivalent: MO-150

Drawing No. C04-072

# PIC16C712/716

---

## APPENDIX A: REVISION HISTORY

### Rev. A Document (6/2000)

First revision of this document.

### Rev. B Document (4/2001)

Added issue 1 (CCP), page 1, and issue 2 (Timer1), page 5.

### Rev. C Document (1/2002)

Under Clarifications/Corrections to the Data Sheet, Item 5 (SSOP), on page 8 was added.

### Rev. D Document (3/2003)

Under Clarifications/Corrections to the Data Sheet, Item 5, Packaging: correct package data was added.

---

**Note the following details of the code protection feature on Microchip devices:**

- Microchip products meet the specification contained in their particular Microchip Data Sheet.
- Microchip believes that its family of products is one of the most secure families of its kind on the market today, when used in the intended manner and under normal conditions.
- There are dishonest and possibly illegal methods used to breach the code protection feature. All of these methods, to our knowledge, require using the Microchip products in a manner outside the operating specifications contained in Microchip's Data Sheets. Most likely, the person doing so is engaged in theft of intellectual property.
- Microchip is willing to work with the customer who is concerned about the integrity of their code.
- Neither Microchip nor any other semiconductor manufacturer can guarantee the security of their code. Code protection does not mean that we are guaranteeing the product as "unbreakable."

Code protection is constantly evolving. We at Microchip are committed to continuously improving the code protection features of our products. Attempts to break microchip's code protection feature may be a violation of the Digital Millennium Copyright Act. If such acts allow unauthorized access to your software or other copyrighted work, you may have a right to sue for relief under that Act.

---

Information contained in this publication regarding device applications and the like is intended through suggestion only and may be superseded by updates. It is your responsibility to ensure that your application meets with your specifications. No representation or warranty is given and no liability is assumed by Microchip Technology Incorporated with respect to the accuracy or use of such information, or infringement of patents or other intellectual property rights arising from such use or otherwise. Use of Microchip's products as critical components in life support systems is not authorized except with express written approval by Microchip. No licenses are conveyed, implicitly or otherwise, under any intellectual property rights.

**Trademarks**

The Microchip name and logo, the Microchip logo, KEELOQ, MPLAB, PIC, PICmicro, PICSTART, PRO MATE and PowerSmart are registered trademarks of Microchip Technology Incorporated in the U.S.A. and other countries.

FilterLab, microID, MXDEV, MXLAB, PICMASTER, SEEVAL and The Embedded Control Solutions Company are registered trademarks of Microchip Technology Incorporated in the U.S.A.

Accuron, Application Maestro, dsPIC, dsPICDEM, dsPICDEM.net, ECONOMONITOR, FanSense, FlexROM, fuzzyLAB, In-Circuit Serial Programming, ICSP, ICEPIC, microPort, Migratable Memory, MPASM, MPLIB, MPLINK, MPSIM, PICC, PICkit, PICDEM, PICDEM.net, PowerCal, PowerInfo, PowerMate, PowerTool, rLAB, rPIC, Select Mode, SmartSensor, SmartShunt, SmartTel and Total Endurance are trademarks of Microchip Technology Incorporated in the U.S.A. and other countries.

Serialized Quick Turn Programming (SQTP) is a service mark of Microchip Technology Incorporated in the U.S.A.

All other trademarks mentioned herein are property of their respective companies.

© 2003, Microchip Technology Incorporated, Printed in the U.S.A., All Rights Reserved.

 Printed on recycled paper.

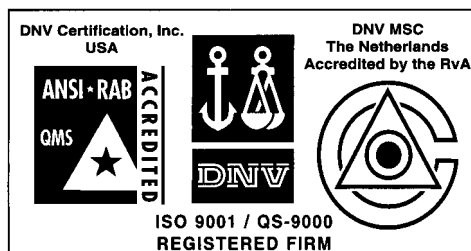

*Microchip received QS-9000 quality system certification for its worldwide headquarters, design and wafer fabrication facilities in Chandler and Tempe, Arizona in July 1999 and Mountain View, California in March 2002. The Company's quality system processes and procedures are QS-9000 compliant for its PICmicro® 8-bit MCUs, KEELOQ® code hopping devices, Serial EEPROMs, microperipherals, non-volatile memory and analog products. In addition, Microchip's quality system for the design and manufacture of development systems is ISO 9001 certified.*



# MICROCHIP

## WORLDWIDE SALES AND SERVICE

### AMERICAS

#### Corporate Office

2355 West Chandler Blvd.  
Chandler, AZ 85224-6199  
Tel: 480-792-7200 Fax: 480-792-7277  
Technical Support: 480-792-7627  
Web Address: <http://www.microchip.com>

#### Atlanta

3780 Mansell Road, Suite 130  
Alpharetta, GA 30022  
Tel: 770-640-0034 Fax: 770-640-0307

#### Boston

2 Lan Drive, Suite 120  
Westford, MA 01886  
Tel: 978-692-3848 Fax: 978-692-3821

#### Chicago

333 Pierce Road, Suite 180  
Itasca, IL 60143  
Tel: 630-285-0071 Fax: 630-285-0075

#### Dallas

4570 Westgrove Drive, Suite 160  
Addison, TX 75001  
Tel: 972-818-7423 Fax: 972-818-2924

#### Detroit

Tri-Atria Office Building  
32255 Northwestern Highway, Suite 190  
Farmington Hills, MI 48334  
Tel: 248-538-2250 Fax: 248-538-2260

#### Kokomo

2767 S. Albright Road  
Kokomo, Indiana 46902  
Tel: 765-864-8360 Fax: 765-864-8387

#### Los Angeles

18201 Von Karman, Suite 1090  
Irvine, CA 92612  
Tel: 949-263-1888 Fax: 949-263-1338

#### Phoenix

2355 West Chandler Blvd.  
Chandler, AZ 85224-6199  
Tel: 480-792-7966 Fax: 480-792-4338

#### San Jose

Microchip Technology Inc.  
2107 North First Street, Suite 590  
San Jose, CA 95131  
Tel: 408-436-7950 Fax: 408-436-7955

#### Toronto

6285 Northam Drive, Suite 108  
Mississauga, Ontario L4V 1X5, Canada  
Tel: 905-673-0699 Fax: 905-673-6509

### ASIA/PACIFIC

#### Australia

Microchip Technology Australia Pty Ltd  
Marketing Support Division  
Suite 22, 41 Rawson Street  
Epping 2121, NSW  
Australia  
Tel: 61-2-9868-6733 Fax: 61-2-9868-6755

#### China - Beijing

Microchip Technology Consulting (Shanghai)  
Co., Ltd., Beijing Liaison Office  
Unit 915  
Bei Hai Wan Tai Bldg.  
No. 6 Chaoyangmen Beidajie  
Beijing, 100027, No. China  
Tel: 86-10-85282100 Fax: 86-10-85282104

#### China - Chengdu

Microchip Technology Consulting (Shanghai)  
Co., Ltd., Chengdu Liaison Office  
Rm. 2401-2402, 24th Floor,  
Ming Xing Financial Tower  
No. 88 TIDU Street  
Chengdu 610016, China  
Tel: 86-28-86766200 Fax: 86-28-86766599

#### China - Fuzhou

Microchip Technology Consulting (Shanghai)  
Co., Ltd., Fuzhou Liaison Office  
Unit 28F, World Trade Plaza  
No. 71 Wusi Road  
Fuzhou 350001, China  
Tel: 86-591-7503506 Fax: 86-591-7503521

#### China - Hong Kong SAR

Microchip Technology Hongkong Ltd.  
Unit 901-6, Tower 2, Metroplaza  
223 Hing Fong Road  
Kwai Fong, N.T., Hong Kong  
Tel: 852-2401-1200 Fax: 852-2401-3431

#### China - Shanghai

Microchip Technology Consulting (Shanghai)  
Co., Ltd.  
Room 701, Bldg. B  
Far East International Plaza  
No. 317 Xian Xia Road  
Shanghai, 200051  
Tel: 86-21-6275-5700 Fax: 86-21-6275-5060

#### China - Shenzhen

Microchip Technology Consulting (Shanghai)  
Co., Ltd., Shenzhen Liaison Office  
Rm. 1812, 18/F, Building A, United Plaza  
No. 5022 Binhe Road, Futian District  
Shenzhen 518033, China  
Tel: 86-755-82901380 Fax: 86-755-82966626

#### China - Qingdao

Rm. B505A, Fullhope Plaza,  
No. 12 Hong Kong Central Rd.  
Qingdao 266071, China  
Tel: 86-532-5027355 Fax: 86-532-5027205

#### India

Microchip Technology Inc.  
India Liaison Office  
Marketing Support Division  
Divyasree Chambers  
1 Floor, Wing A (A3/A4)  
No. 11, O'Shaughnessey Road  
Bangalore, 560 025, India  
Tel: 91-80-2290061 Fax: 91-80-2290062

### Japan

Microchip Technology Japan K.K.  
Benex S-1 6F  
3-18-20, Shinyokohama  
Kohoku-Ku, Yokohama-shi  
Kanagawa, 222-0033, Japan  
Tel: 81-45-471-6166 Fax: 81-45-471-6122

### Korea

Microchip Technology Korea  
168-1, Youngbo Bldg. 3 Floor  
Samsung-Dong, Kangnam-Ku  
Seoul, Korea 135-882  
Tel: 82-2-554-7200 Fax: 82-2-558-5934

### Singapore

Microchip Technology Singapore Pte Ltd.  
200 Middle Road  
#07-02 Prime Centre  
Singapore, 188980  
Tel: 65-6334-8870 Fax: 65-6334-8850

### Taiwan

Microchip Technology (Barbados) Inc.,  
Taiwan Branch  
11F-3, No. 207  
Tung Hua North Road  
Taipei, 105, Taiwan  
Tel: 886-2-2717-7175 Fax: 886-2-2545-0139

### EUROPE

#### Austria

Microchip Technology Austria GmbH  
Durisolstrasse 2  
A-4600 Wels  
Austria  
Tel: 43-7242-2244-399  
Fax: 43-7242-2244-393

#### Denmark

Microchip Technology Nordic ApS  
Regus Business Centre  
Lautrup høj 1-3  
Ballerup DK-2750 Denmark  
Tel: 45 4420 9895 Fax: 45 4420 9910

#### France

Microchip Technology SARL  
Parc d'Activite du Moulin de Massy  
43 Rue du Saule Trapu  
Batiment A - 1er Etage  
91300 Massy, France  
Tel: 33-1-69-53-63-20 Fax: 33-1-69-30-90-79

#### Germany

Microchip Technology GmbH  
Steinheilstrasse 10  
D-85737 Ismaning, Germany  
Tel: 49-89-627-144-0  
Fax: 49-89-627-144-44

#### Italy

Microchip Technology SRL  
Via Quasimodo, 12  
20025 Legnano (MI)  
Milan, Italy  
Tel: 39-0331-742611 Fax: 39-0331-466781

#### United Kingdom

Microchip Ltd.  
505 Eskdale Road  
Winnersh Triangle  
Wokingham  
Berkshire, England RG41 5TU  
Tel: 44 118 921 5869 Fax: 44-118 921-5820

03/25/03