

PART NO.	PLATING	HEX NUT
903-048	SEE FINISH NOTE	903-048-1
903-048-1	PLAIN	N/A

THREAD DIM'S BEFORE PLATING:  
 MAJOR DIA. .625 MIN.  
 PITCH DIA. .5889 / .5949  
 MINOR DIA. .565 / .570

THREAD DIM'S AFTER PLATING:  
 MAJOR DIA. .623 MIN.  
 PITCH DIA. .5869 / .5929  
 MINOR DIA. .563 / .568

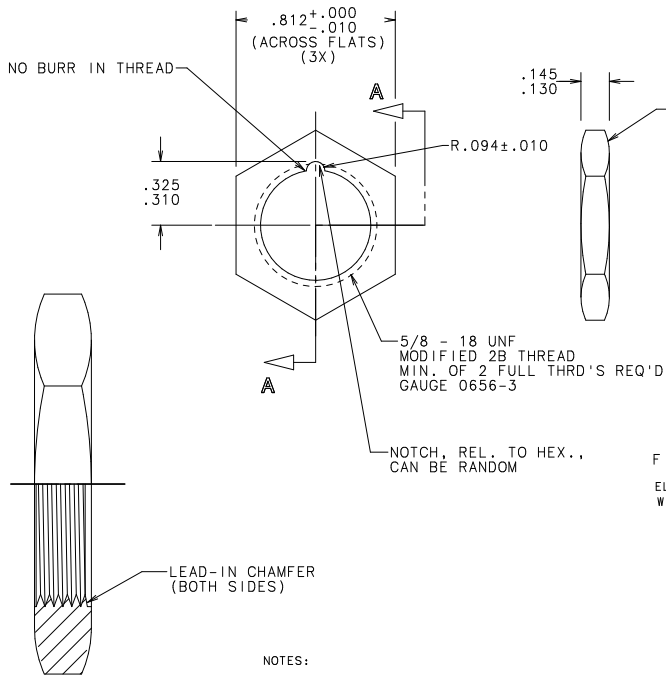

NOTES:

1. AXIS OF THREAD TO BE ⊥ WITHIN 2° TO FACE OF NUT.
2. ESSENTICITY OF P.D. & MAJOR DIA. NOT TO EXCEED .010 T.I.R.
3. ECCENTRICITY OF MIN. DIA. TO FLATS NOT TO EXCEED .010 T.I.R.
4. UNPLATED PARTS TO BE PROTECTED AGAINST OXIDATION UNTIL PLATED, PLATING TO BE DONE AS SOON AS POSSIBLE AFTER FABRICATION.
5. PLATED PARTS SHALL MEET THE SALT SPRAY REQUIREMENTS OF ASTM-B117 96 HR. SALT SPRAY TEST (CERTIFICATION REQUIRED).

SECTION A-A

SCALE 4:1

FINISH NOTE:

ELECTRODEPOSITED ZINC COATING WITH SUPPLEMENTARY FINISH PER:  
 0.0003 +0.0003 MINIMUM ZINC PLATING  
 -0.0000  
 SERVICE CONDITION SC3  
 TYPE II YELLOW CHROMATE CONVERSION COATING (SEE NOTE 5)

EA	QTY/M	DESCRIPTION
1000		

BILL OF MATERIAL							
COPIES TO	MATERIAL SPEC	FINISH		SCALE		FULL	LBS/M
		M.F.T.P. (F-0000000000)	DATE	12/8/97			
1	9	DRW	KAM				
2	10	18					
3	12	20	CHK				
4	13	21	APPD				
5	14	23					
6	15	33					
7	16	43					
8	17	53					

HEX NUT-SINTERED		SERIES
HEX NUT-SINTERED		903-048
HEXAGON	DRWNG. NO.	
V		
DES PLAINES, ILL INOIS 60016		

LTR	REVISION	CHK	APD
S	39046C-REVISE & REDRAWN IN NEW STRUCTURE 3/30/98 KAM		
T	80518C - ADD FINISH NOTE, CHG. NOTE 5, ADD CHART,		
-	REMOVE FROM B/M ZINC ANODE 4/4/2000 BJJ		
U	81992B-DLT. *ASTM* ADD TOL FOR PLATING 4/3/02 PJM		
V	82142D-CHG *00005-20 TO *00006.85 MIN. DEN. 3/22/02 PJM		

UNLESS OTHERWISE SPECIFIED, DIMENSIONS DO NOT INCLUDE PLATING.

UNLESS OTHERWISE SPECIFIED, DIMENSIONS DO NOT INCLUDE PLATING.

UNLESS OTHERWISE SPECIFIED, DIMENSIONS DO NOT INCLUDE PLATING.

UNLESS OTHERWISE SPECIFIED, DIMENSIONS DO NOT INCLUDE PLATING.

UNLESS OTHERWISE SPECIFIED, DIMENSIONS DO NOT INCLUDE PLATING.

UNLESS OTHERWISE SPECIFIED, DIMENSIONS DO NOT INCLUDE PLATING.

UNLESS OTHERWISE SPECIFIED, DIMENSIONS DO NOT INCLUDE PLATING.

UNLESS OTHERWISE SPECIFIED, DIMENSIONS DO NOT INCLUDE PLATING.

UNLESS OTHERWISE SPECIFIED, DIMENSIONS DO NOT INCLUDE PLATING.

UNLESS OTHERWISE SPECIFIED, DIMENSIONS DO NOT INCLUDE PLATING.

UNLESS OTHERWISE SPECIFIED, DIMENSIONS DO NOT INCLUDE PLATING.

UNLESS OTHERWISE SPECIFIED, DIMENSIONS DO NOT INCLUDE PLATING.

UNLESS OTHERWISE SPECIFIED, DIMENSIONS DO NOT INCLUDE PLATING.

UNLESS OTHERWISE SPECIFIED, DIMENSIONS DO NOT INCLUDE PLATING.

UNLESS OTHERWISE SPECIFIED, DIMENSIONS DO NOT INCLUDE PLATING.

UNLESS OTHERWISE SPECIFIED, DIMENSIONS DO NOT INCLUDE PLATING.

UNLESS OTHERWISE SPECIFIED, DIMENSIONS DO NOT INCLUDE PLATING.

UNLESS OTHERWISE SPECIFIED, DIMENSIONS DO NOT INCLUDE PLATING.

UNLESS OTHERWISE SPECIFIED, DIMENSIONS DO NOT INCLUDE PLATING.

UNLESS OTHERWISE SPECIFIED, DIMENSIONS DO NOT INCLUDE PLATING.

