

© 1969 BY AMP INCORPORATED. ALL RIGHTS RESERVED. AMP PRODUCTS COVERED BY PATENTS AND/OR PATENTS PENDING.

THIS PRODUCT DESIGNED AND BUILT BY AMP INCORPORATED. NO LICENSE TO USE THAT DESIGN OR MANUFACTURE, OR TO USE ANY ISSUED OR PENDING PATENTS WHICH ARE INVOLVED, IS IMPLIED.

REVISIONS				
ZONE	LTR	DESCRIPTION	DATE	APPROVED
A		REF SK 26799-A REVISED & REDRAWN	4-1-69	KWK
B		REVISED NOTE 1 ECN 8383	9-5-78	M.H.
C		ECN 8983	10-31-79	M.H.
D		ADDED PANEL CUTOUT DIMS	8-18-83	B.M.
E		REV. PER ECN L1309	2-12-85	S.M.
F		OBSOLETE ECN 53614	1-19-87	R.B.
G		REV PER DF4286	7/3/91	Don Eaby
H		REV PER ECD-07-005995	4-3-07	Don Eaby

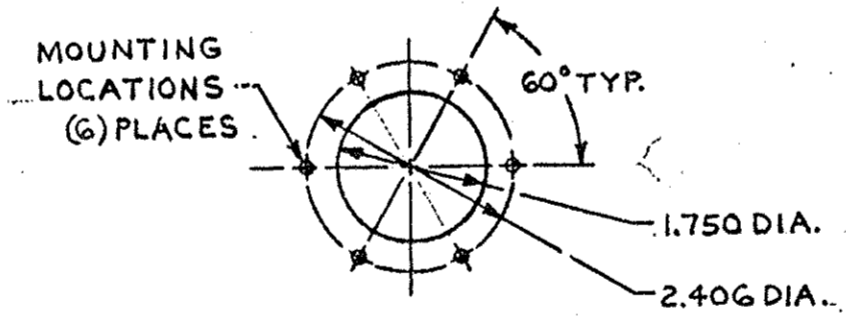
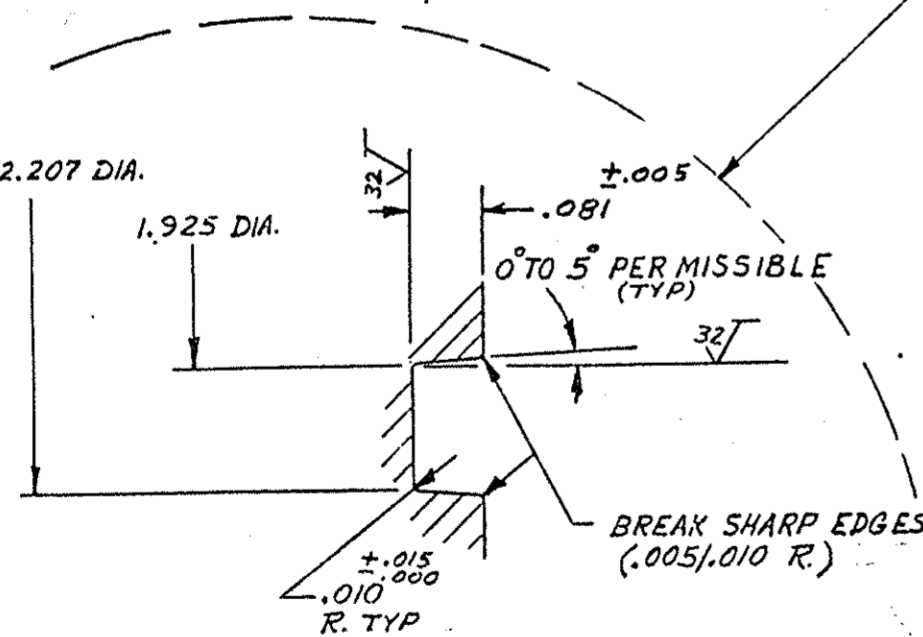
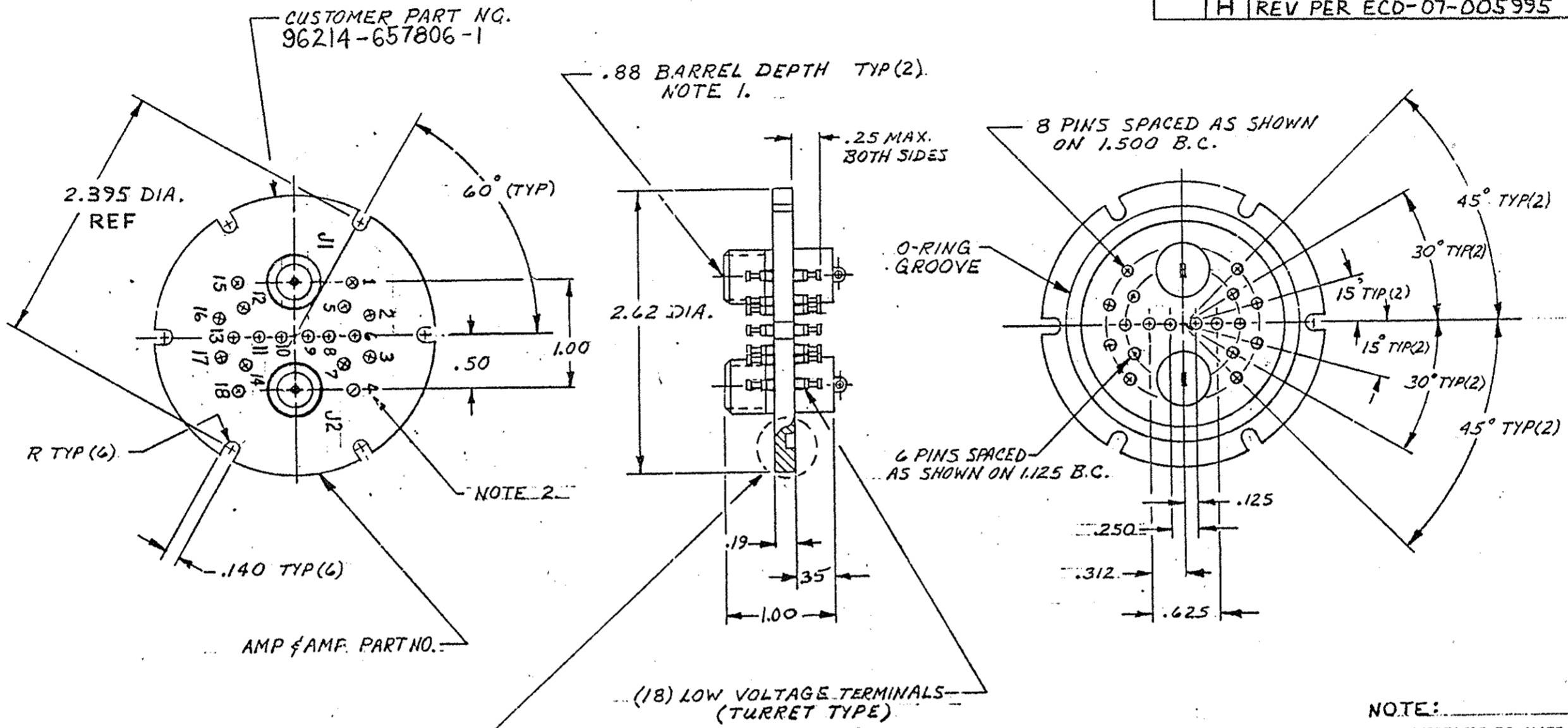

RECOMMENDED PANEL CUT OUT HALF SCALE

- NOTE:
1. RECEPTACLE TO MATE WITH AMP LGH-1 LEAD ASSEMBLY. AVAILABLE SEPARATELY.
 2. MARK CUSTOMER NO. & AMP & AMP PART NO. AS SHOWN - RUBBER STAMP COLOR TO BE WHITE. APPROX .12 HIGH
 3. ALL LOW VOLTAGE TERMINALS, GROUND TO 600 V MAX & 600 V TERMINAL TO TERMINAL
 4. CONNECTOR IS HERMETIC SEALED.

QTY REQD	QTY REQD	ITEM NO.	DWG SIZE	PART OR IDENTIFYING NO.	NOMENCLATURE OR DESCRIPTION	SYMBOL
-2	-1			849515-1	AS SHOWN	

QTY REQD	FINAL ASSY	NEXT ASSY	USED ON	APPLICATION

UNLESS OTHERWISE SPECIFIED:
 DIMENSIONS ARE IN INCHES
 TOLERANCES
 .00 = ±.02 ANGLES = ±1°
 .000 = ±.005

MATERIAL:
 MOLDED GLASS EPOXY (BLACK)

FINISH:

CONTRACT NO.,
 DR L. GEIB 1-29-69
 GHK
 APPD E. JOHNSON 1-30-69
 APPD
 DESGN APPD
 OTHER APPD

AMP INCORPORATED
 CAPITRON DIVISION
 ELIZABETHTOWN, PENNSYLVANIA

NAME
 INTERFACE CONNECTOR (18) LOW VOLTAGE (2) HIGH VOLTAGE

WJH

SIZE C CODE IDENT NO. 00779 NUMBER 849515

SCALE WT SHEET REV

PRINT DIST. LOC. L/SO DE

UPDATED