

THIS DRAWING IS UNPUBLISHED. RELEASED FOR PUBLICATION ,19 .  
 © COPYRIGHT 19 BY AMP INCORPORATED. ALL RIGHTS RESERVED.

LOC	DIST	REVISIONS			
P	LTR	DESCRIPTION	DATE	DWN	APVD
G	14	E	REL -1 PER PR 96-3010-001	20AUG96	ME SB

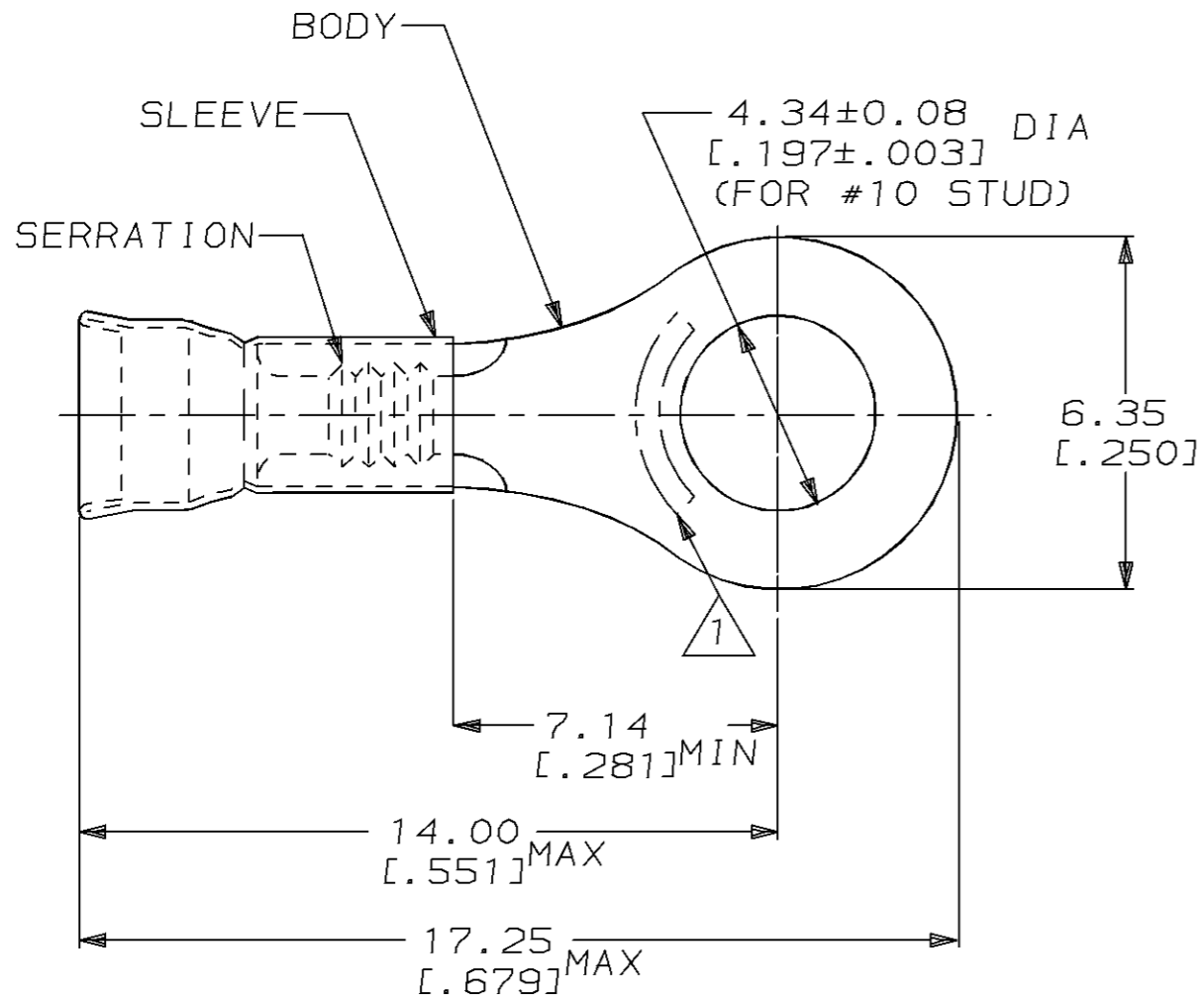

△ STAMP AMP LOCATE APPROX AS SHOWN

- 2. WIRE INSUL DIA, 1.27-2.08 [.050-.082]
- 3. TONGUE MATL THK, 0.46±0.05 [.018±.002]

-	-	-
1000	LOOSE PIECE	32863-1
QTY	PACKAGE TYPE	PART NO

AMP INCORPORATED CUSTOMER SERVICE SYSTEM	
FOR ADDITIONAL PRODUCT INFORMATION OR COPIES OF DRAWINGS AND TECHNICAL DOCUMENTS	PRODUCT INFORMATION CENTER 1-800-522-6752
FOR APPLICATION TOOLING INFORMATION	TOOLING ASSISTANCE CENTER 1-800-722-1111
FOR ORDER ENTRY	1-800-526-5142

MAX RECOMMENDED OPERATING TEMPERATURE: -
VOLTAGE RATING: -
CIRCULAR MIL AREA: 0.10mm <sup>2</sup> -0.41mm <sup>2</sup> [202-#10]
STRANDED WIRE

THIS DRAWING IS A CONTROLLED DOCUMENT FOR AMP INCORPORATED. IT IS SUBJECT TO CHANGE AND THE CONTROLLING ENGINEERING ORGANIZATION SHOULD BE CONTACTED FOR THE LATEST REVISION.	
DIMENSIONS: mm [in]	TOLERANCES UNLESS OTHERWISE SPECIFIED:
	0 PLC ±-
	1 PLC ±-
	2 PLC ±0.20 [.008]
	3 PLC ±-
	4 PLC ±-
ANGLES ±-	
MATERIAL BODY, CU, SLV, CU PER ASTM B152	FINISH GOLD PLT PER MIL-6-45204 OVER NICKEL PLT. PER QQ-N-290

DWN	L OLMEDA	23JAN95
CHK	M ELLIS	23JAN95
APVD	S BORTNER	23JAN95
PRODUCT SPEC	-	-
APPLICATION SPEC	-	-
WEIGHT	-	-
CUSTOMER DRAWING		

AMP Incorporated Harrisburg, PA 17105-3608		
NAME TERMINAL, RING, DIAMOND GRIP™, WIRE SIZE, 26-22 AWG		
SIZE	CAGE CODE	DRAWING NO
A3	00779	C-32863
SCALE	SHEET	REV
6:1	1 OF 1	E