

SPECIFICATION

SPEC. No. _____

DATE: _____

To

For Automotive

CUSTOMER'S PRODUCT NAME

TDK'S PRODUCT NAME

Ceramic insulated capacitors disc type safety standard

TYPE : C S × × Δ Δ 2 G A O O O □ A ◇ K A

RECEIPT CONFIRMATION

DATE: _____ YEAR _____ MONTH _____ DAY _____

TDK Corporation

Sales

Electronic Components Sales &
Marketing Group

Engineering

Ceramic Capacitors Business Group .

APPROVED	Person in charge

APPROVED	CHECKED	Person in charge

Handling precautions for High voltage ceramic capacitors

Please read the following closely before using these products.

Safety precautions

The following precautions should be observed strictly to ensure safety design.
Misuse of the product may lead to smoking of the product.



Cautions

1. Operating voltage

Use within the rated voltage of capacitor between terminals. For DC rated voltage application, you should control the peak voltage (V_{0-P}) under the rated voltage in case the AC voltage is superimposed on the DC voltage. Use within the rated voltage includes peak voltage (V_{P-P}) when AC voltage or impulse voltage applied in a circuit. Confirm irregular voltage (surge voltage, static electricity, switching noise, etc) occurs in the equipment used, and use within the rated voltage containing the irregular voltage.

When the capacitor is used as a noise suppressor in the AC primary circuit, the voltage proof test should be within the specified conditions (voltage, time, wave form, etc).

Connect by confirmation of non lose contact, and the voltage is started to apply to the circuit from zero to the specified voltage and it is stopped applying from the voltage to zero.

Voltage	(1) DC voltage	(2) DC+AC voltage	(3) AC voltage	(4) Pulse voltage
Voltage Measuring position				

2. Operating temperature

Be sure to use only those operating temperature described in our catalogue or specification.

Keep the surface temperature under the maximum temperature, which includes the maximum self-heat temperature of 20 degree C.

3. Self-exothermal

Self-exothermal temperature should be within 20 degree C on the condition of atmosphere temperature 25 degree C without the influence of wind such as the cooling fan. Be sure to use a capacitor in a circuit of current increase by AC voltage or pulse voltage applied.

When high frequency voltage or impulse voltage applied in a circuit, reliability should be influenced. Take into considerations the load reduction and self-exothermal temperature, even if voltage should be within the rated voltage.

PLP Spec No.

HV095F19



Cautions

4. Capacitance change of capacitors

For some of the capacitors, capacitance value may change considerably in the temperature range, or by applied DC voltage. And capacitor has aging characteristic (capacitance decreases by keeping as it is). When you use the capacitor in the time constant circuit, consult TDK whether the capacitor is available or not.

5. Vibration of capacitors

When the capacitor class 2 is used in the AC circuit, or pulse circuit, the capacitor might vibrate or noise might occur in the specified frequency. Be sure to confirm the conditions before using the capacitor.

6. Usage of capacitance and storage

Don't use capacitors in the following environments:

- * Direct sunshine
- * Areas directly exposed to water or salty water
- * Areas that become dewy
- * Areas filled with toxic gases (such as hydrogen sulfide, sulfur dioxide, chlorine, ammonia, etc)
- * Areas exposed to excess vibrations or shock conditions described in our catalogue or specification.

Store capacitors in an environment from -10 to 40 degree C, with 15 to 70%RH for 6 months maximum and use within the period after receiving the capacitors.

7. Inserting precautions

When inserting capacitors into the PC board by automatic insertion machine, confirm the conditions (such as pressure of pusher, adjustment of clinching portion) and minimize the impact force by chucking the body, or clinching the lead terminals.

Distances between the hole position onto a PC board should be equal to the pitch of capacitors.

When stretching the lead terminal, any force may load the bottom of the capacitor body and result in damage to the insulation coating. Severe damages may cause poor reliability.

8. Soldering

Don't immerse the capacitor body into the molten solder, and don't solder the terminals by reflow soldering. Use PC board, and solder the terminals in the opposite side of the body. Soldering conditions, such as pre-heat temperature, soldering temperature, and soldering time, should be followed by the descriptions in our catalogue or specification. (refer to Fig.-1)

Adjust the amount of solder within the proper volume. Select an appropriate soldering material.

When using soldering iron for installing capacitors or reworking onto the PC board, sufficient pre-heating and temperature control should be used. We recommend that the iron condition is 350 ± 10 degree C/ 3.5 ± 0.5 s. as 1 time, and you should use an adequate tip diameter ($\phi 3$ mm Max.) with the soldering iron as well as a proper wattage (50W Max.). Don't touch the capacitor body directly with soldering tip, except for the terminals of capacitor.

9. Flux

When using flux for soldering capacitors onto the PC board, spread it thinly and uniformly.

Flux will be composed of halogenated material less than 0.1 wt% (cl conversion).

Don't use a strong acid grade of flux. When using water-soluble flux, sufficient cleansing should be done.

PLP Spec No.

HV095F19



Cautions

10. Cleansing

When the cleansing should not be sufficient, the cleansing liquid or any residue might leave on the capacitor body, they may deteriorate the insulation coating or performance (insulation resistance, etc.). When using ultrasonic cleansing, avoid transmitting vibrations onto the PC board. Conditions of ultrasonic cleansing, such as output frequency and time of the method, should be taken into considerations.

After cleansing capacitors, dry them well. Cleansing liquid should not contain electrolyte, nor leave any residue. Through the result of the cleansing method, confirm whether the quality of the capacitors have been affected due to the conditions.

11. Coating or molding

When coating or molding capacitors after installing components onto the PC board, confirm whether the performance of capacitors may not be damaged by the work.

12. Mechanical stress

Don't submit to excessive mechanical shock. Don't use capacitors which may have been damaged due to dropping, etc.

If possible, avoid bending the terminals of capacitors. In an unavoidable case of bending, use a small jig to decrease the mechanical stress on the capacitors.

13. Others

Please contact TDK before using our capacitors listed in this catalogue or specifications for the applications listed below which require especially high reliability for the prevention of defects which might directly cause damage to the third party's life, body or property, or when intending to use one of our capacitors for other applications than specified in this catalog or specifications.

- * Medical equipment
- * Aerospace equipment
- * Power plant equipment
- * Aircraft equipment
- * Transportation equipment (vehicles, trains, ships, etc)
- * Undersea equipment
- * Traffic signal equipment
- * Disaster prevention, crime prevention equipment
- * Data processing equipment exerting influence on public
- * Application of similar complexity and, or reliability requirements to the applications listed in the above.

Please refer to the guideline of notabilia for fixed ceramic capacitors issued by JEITA (Japan Electronics and Information Technology Association, EIAJ RCR-2335).

PLP Spec No.

HV095F19

Scope

This specification applies to ceramic insulated capacitors disc type used in circuits of electromagnetic interference suppression in electronic and equipment and approved by IEC60384-14, EN60384-14, UL60384-14 and relative safety standards.

Relative standards

IEC 60384-14、 EN60384-14、 UL60384-14

Mention item

1. Applicable safety standard approval
2. Acquired safety standard approval and Approval report No.
3. Part Name
4. Operating temperature range
5. Test condition
6. Performance
7. Marking
8. Figure & Dimension
9. Label & Transport
10. Notification before the modification

We do not use the following material (1),(2) in these products.

- (1) PBBOs (Poly Bromo Biphenyl Oxides)
- (2) PBBs (Poly Bromo Biphenyls)

We do not use Class I and II ODS (Ozone depleting substances) in all our process of these products.

These products shall conform to RoHS Directive.

These products are Halogen-free.(Br \leq 900ppm, Cl \leq 900ppm, Br+Cl \leq 1500ppm)

Manufacturing place

Manufacturing site should be TDK Taiwan & TDK Xiamen

Division	Date Issued	SPEC. No.
Ceramic Capacitors Business Group		

1. Applicable safety standard

This is specification applies the BSI, VDE, SEV, SEMKO, FIMKO, NEMKO, DEMKO, SAA, IMQ, UL, CSA and CQC,KTL approved ceramic capacitor disc type.

2. Acquired safety standard approval and Approval report No..

Safety Standard	Standard No. of IEC	Standard No.	T.C.	Subclass	W.V	Approval report No.					
						Taiwan	Xiamen				
BSI	BS EN 60384-14 IEC 60384-14	BS EN 60065 (8.8、14.2) BS EN 60384-14	SL, B, Z5U,	X1, Y2	X1:440VAC Y2:300VAC	KM37103					
VDE	IEC 60384-14	EN 60384-14				40017930					
SEV						15.0120					
SEMKO						1406932					
NEMKO						P12215336					
DEMKO						D-01153					
FIMKO						FI 27399					
IMQ						V3692					
SAA						CS6268					
CSA						1785515					
UL						E37861					
CQC						CQC1200 1082619		CQC1000 1052862			
KTL							K60384-14	X1	440V AC	SZ03001 -12006	SU03047 -12006
								Y2	300V AC	SZ03001 -12008	SU03047 -12008

* T.C.: Temperature Characteristic.

* Certificate No(s) shall be changed owing to the revisions of the related standards and renewal of certificate.

3. Part name

(Example)

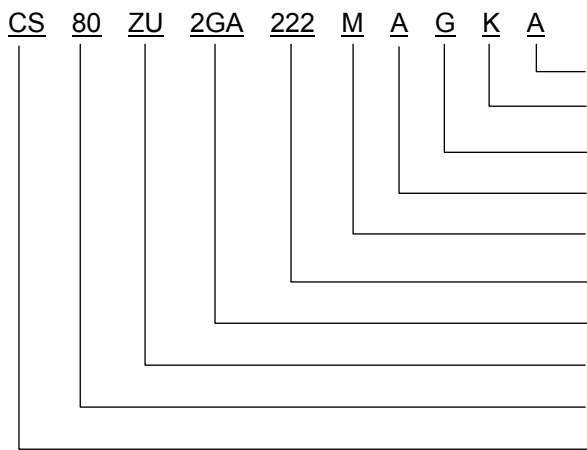

- Halogen-free
- Safety (Miniature Type)
- Lead style ※Note-2
- Automotive use
- Rated capacitance tolerance
- Rated capacitance
- Rated voltage
- Temperature characteristic of capacitance ※Note-1
- Internal control No.
- Type

※ Note-1

Temperature characteristic of capacitance : SL:TC SL, -B:TC B, ZU:TC Z5U

※ Note-2

- Lead style G : Vertical kink long lead (Bulk)
- N : Vertical kink short lead (Bulk)
- V : Vertical kink long lead (Taping)

4. Operating Temperature range : -25 °C to +125 °C

Operating temperature range max. is +125 °C
(Including capacitor's self-heating max. +20 °C)

5. Test condition

Test and measurement shall be made at the standard condition, (Temperature 15 to 35 °C, relative humidity 45 to 75 % and atmospheric pressure 860 to 1060 Pa.), Unless otherwise specification herein. If doubt occurred on the value of measurement, and remeasurement was requested by customer capacitors shall be measured at the reference condition (Temperature 20 ±2 °C ,relative humidity 60 to 70 % and atmospheric pressure 860 to 1060 Pa.)

6. Performance

The performances shall comply with Table-1

Table-1

No.	Items		Performance	Test method
1	Appearance and dimension		The appearance and dimension shall be as given in paragraph 8 and Table-2 to 5	Visual check and measuring with micrometer.
2	Marking		The marking shall be easily legible (Paragraph 7)	Visual check
3	Withstand voltage	Between terminals	No failure	Voltage: 2600V AC (50 or 60 Hz) Test time: 60 s Charge and discharge current shall be 50 mA or less.
		Between terminal and exterior cladding	No failure	2600VAC (50 or 60Hz) shall be applied for 60 s between the terminal connected together and the enclosure of capacitor with metal foil from the distance 4mm of the body.
4	Insulation resistance	Between terminals	10000 MΩ or more	60±5 sec. after application with 500±50V DC.
5	Capacitance		With the tolerances specified with Table-3 to 5	SL: Measuring frequency : 1MHz ±10 % Measuring voltage : 5Vrms. or less B,Z5U
6	Dissipation factor (tanδ)		SL : 0.5 % or less B, Z5U: 2.5 % or less	Measuring frequency : 1kHz ±20 % Measuring voltage : 5Vrms. or less
7	Capacitance temperature characteristic (No voltage application)		SL :Within -1000 to +350ppm/°C B :Within ± 10% Z5U:Within - 56% to + 22%	Standard temperature: 20°C (Z5U: 25°C) Temperature range: SL: +20 to +85°C B,F: -25 to +85°C Z5U: +10 to +85°C Initial :pre-heat 125±2°C, 1h, Leaving room temp. for24±2h.
8	Strength of terminal	Tensile strength	Lead wire shall not be disconnected, and capacitor shall not be damaged.	The force of 10N shall be applied to the axial direction of the termination.
		Bending strength	Lead wire shall not be disconnected, and capacitor shall not be damaged.	The force of 5N shall be applied to the axial direction of the terminal and the body shall be inclined through an angle of 90 degrees, then the body shall be returned to the original position. Furthermore the body shall be inclined to the other direction of 90 degrees. This operation shall be carried out two times.
9	Vibration resistance	Appearance	No marked defect	Displacement: 1.5mm Acceleration: 5G Vibration frequency range:10 to 2000 to 10 Hz shall be one set/20 min. An inspection performs the direction of XYZ 12 times, respectively, and is a total of 36 times. Capacitor is fixed by resin 
		Capacitance change	Within the tolerances specified with No.5	
		Dissipation factor (tan δ)	Within the value specified with No.6	

Table-1 Continue

No.	Items	Performance	Test method
10	Resistance to soldering heat	Appearance	No marked defect
		Capacitance change	Within : ± 10 %
		Withstand voltage (Between terminals)	No failure
11	Solderability	At least 3/4 of circumferential dipped into solder shall be covered with new solder.	Soldering temperature : 245 ± 5 °C Dipping time : 2 ± 0.5 sec. Concentration of solution shall be about 25 % colophonium in weight ratio
12	Heat shock test	Appearance	No marked defect
		Capacitance change	SL、 B : Within ± 10 % Z5U : Within ± 20 %
		Dissipation factor ($\tan \delta$)	SL : 1.0 % or less B, Z5U: 5.0 % or less
		Insulation resistance	3000 M Ω or more
		Withstand voltage (Between terminals)	No failure
13	Moisture resistance (Steady state)	Appearance	No marked defect
		Capacitance change	Within ± 15 %
		Insulation resistance	3000 M Ω or more
		Withstand voltage	No failure
14	Moisture resistance loading	Appearance	No marked defect
		Capacitance change	Within ± 15 %
		Insulation resistance	3000 M Ω or more
		Withstand voltage	No failure
15	High temperature loading	Appearance	No marked defect
		Capacitance change	Within ± 20 %
		Insulation resistance	3000 M Ω or more
		Withstand Voltage	No failure
16	Impact test	Appearance	No marked defect
		Capacitance change	Within ± 20 %
		Insulation resistance	3000 M Ω or more
		Withstand Voltage	No failure
			Waveform : Half-sine Acceleration : 100G Time:6msec X, Y, Z, and reverse direction. 3 times each Capacitor is fixed by resin. 

7. Marking

Marking on one side.

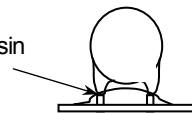
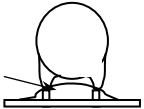
(1) Type : CS

(2) Rated capacitance tolerance

Example 2200 pF : 222

±20 % : M

(3) Subclass

Sub class	Rated voltage	Marking
X1	440 V AC	440~X1
Y2	300 V AC	300~Y2

(4) Manufacture's trade mark

	Taiwan
	Xiamen

(5) Date code : 57 ※ Note-1

Example

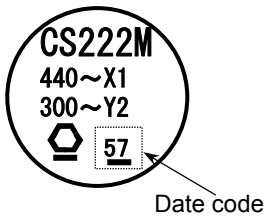

※Note-1 Date code

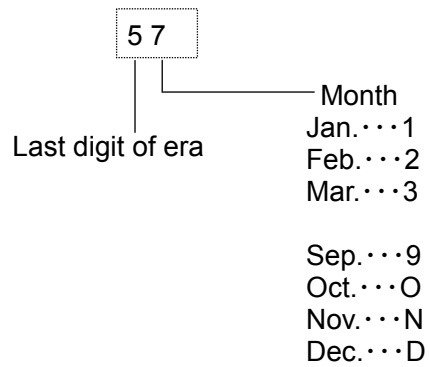

(6) Automotive use

The horizontal line under Date Code

8. Figure & dimension

8.1 Vertical kink long lead (Lead style: G / Bulk)

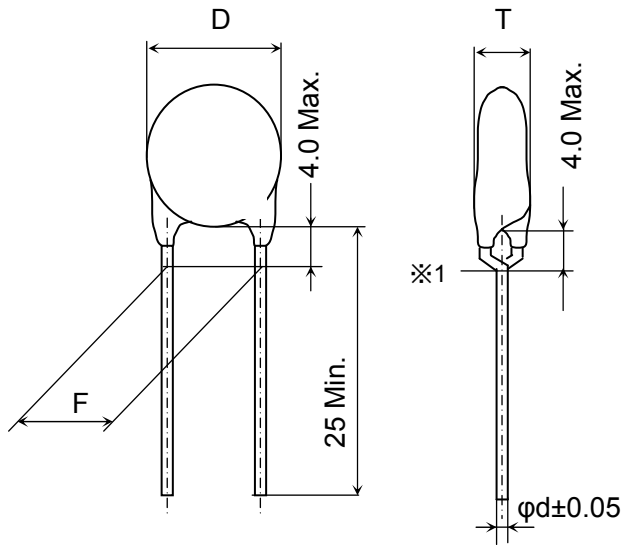

8.2 Vertical kink short lead (Lead style: N / Bulk)

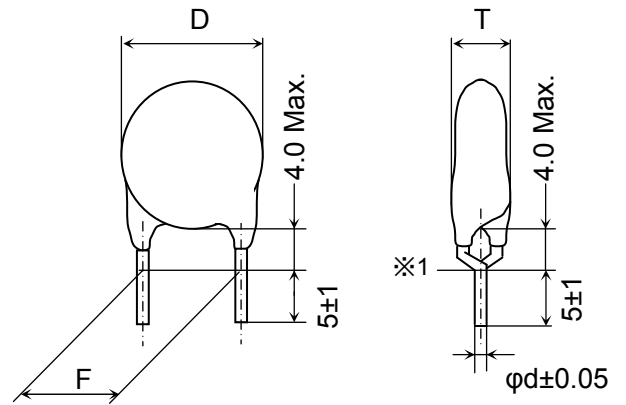

※1 Coating on lead shall not extend beyond the bottom of vertical kink.

Unit : mm

Coating material: Epoxy resin (Color: Blue)

(Flame class): UL94, V-0

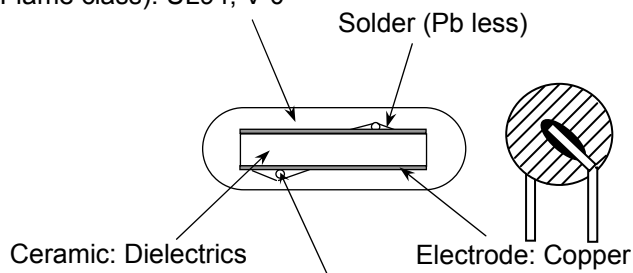

Lead wire: CP wire (Tin plated copper covers steel wire, Pb less)

※2 Coating thickness is 0.4mm Min. from the live part.

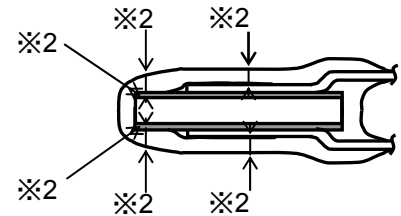

8.3 Vertical kink long lead (lead style: V / Taping)

(F=7.5mm, Pitch: 15.0mm)

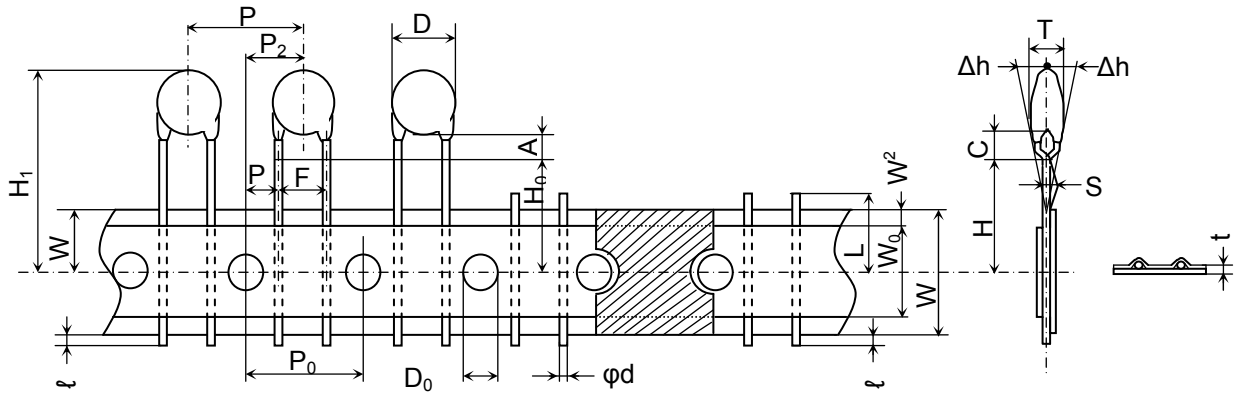

Table-2

Unit: mm

Item Name	Symbol	Dimension	Remarks
Body diameter	D	Table-5	
Body thickness	T	Table-5	
Lead-wire diameter	ϕd	0.6 ±0.05	
Pitch of component	P	15.0 ±1.0	Including the slant of body
Feed hole pitch	P_0	15.0 ±0.3	Excepting the tape splicing part
Feed hole center to lead	P_1	3.75 ±0.7	
Feed hole center to component	P_2	7.5±1.3	Including the slanting body due to bending lead-wire
Lead-to lead distanc	F	7.5±0.8	Measuring point is bottom kink
Component alignment, F-R	Δh	0 ± 2.0	Including the slanting body due to bending lead-wire
Tape width	W	18+1.0,-0.5	
Adhesive tape width	W_0	10.0 Min.	
Hole position	W_1	9.0 ±0.5	
Adhesive tape position	W_2	4.0 Max.	Adhesive tape do not stick out the tape
Bottom of kink from tape center	H_0	16 +1.5,-0.5	
Height of body from tape center	H_1	46.0 Max.	
Lead-wire protrusion	ℓ	1.0 Max.	
Feed hole diameter	D_0	4.0 ±0.2	
Total tape thickness	t	0.6 ±0.3	Including adhesive tape
Length of snapped lead	L	11.0 Max.	
Coating on lead	C	4.0 Max.	
Height of kink	A	4.0 Max.	Measuring point is bottom of kink
Spring action	S	2.0 Max.	

- Note-1 Use the gummed tape to connect two ends of broken tape.
- Note-2 Dropouts of parts shall be limited to no more than three consecutive parts.
- Note-3 Packaging method and dimensions see below.
- Note-4 Quantity Pitch: 15.0mm 1000 pcs. /Box.

Packaging : Ammo pack

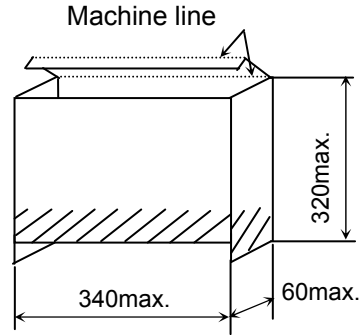
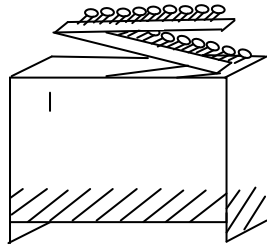

Unit:mm

Note-5 Package of shipment
Capacitors pack in downward

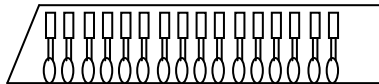

9. Label and transport

Capacitors shall be packaged prior to shipment so as to prevent damage during transportation and storage. Shipping carton contains the following information on the label.

- a) TDK item name
- b) Quantity
- c) TDK inspection number
- d) Manufacturer's name
- e) Country of origin

Bulk

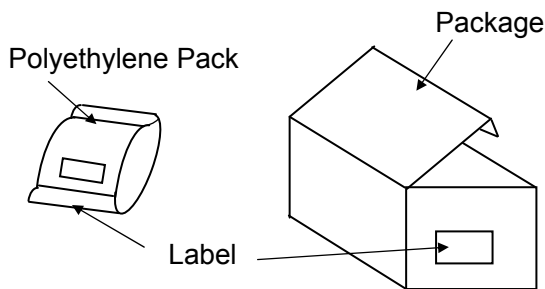

Taping

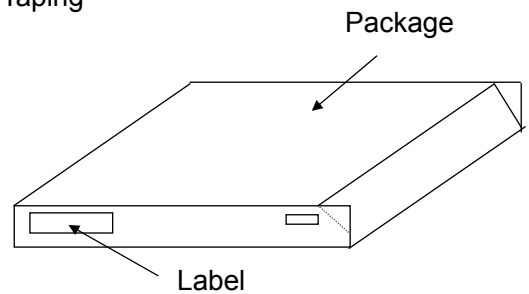

10. Notification before the modification

We'll previously notify the modified place of manufacture, manufactured articles and materials.

Type : CS
 T.C : SL, B, Z5U

Vertical kink long lead (lead style: G / bulk)

Table-3

Your part No	TDK part No.	T.C.	Cap. (pF)	C-Tol. (%)	Dimension (Unit : mm)			
					D Max.	T Max.	F	φd
	CS45SL2GA100JAGKA	SL	10	± 5	7.0	7.0	7.5±1.5	0.6
	CS45SL2GA150JAGKA	SL	15	± 5	7.0	7.0	7.5±1.5	0.6
	CS45SL2GA220JAGKA	SL	22	± 5	7.0	7.0	7.5±1.5	0.6
	CS45SL2GA330JAGKA	SL	33	± 5	7.0	7.0	7.5±1.5	0.6
	CS45SL2GA470JAGKA	SL	47	± 5	8.0	7.0	7.5±1.5	0.6
	CS45SL2GA680JAGKA	SL	68	± 5	9.0	7.0	7.5±1.5	0.6
	CS65-B2GA101KAGKA	B	100	± 10	7.0	7.0	7.5±1.5	0.6
	CS65-B2GA151KAGKA	B	150	± 10	7.0	7.0	7.5±1.5	0.6
	CS65-B2GA221KAGKA	B	220	± 10	7.0	7.0	7.5±1.5	0.6
	CS70-B2GA331KAGKA	B	330	± 10	7.5	7.0	7.5±1.5	0.6
	CS75-B2GA471KAGKA	B	470	± 10	9.0	7.0	7.5±1.5	0.6
	CS85-B2GA681KAGKA	B	680	± 20	9.5	7.0	7.5±1.5	0.6
	CS65ZU2GA102MAGKA	Z5U	1000	± 20	7.0	7.0	7.5±1.5	0.6
	CS75ZU2GA152MAGKA	Z5U	1500	± 20	8.0	7.0	7.5±1.5	0.6
	CS80ZU2GA222MAGKA	Z5U	2200	± 20	9.5	7.0	7.5±1.5	0.6
	CS95ZU2GA332MAGKA	Z5U	3300	± 20	12.0	7.0	7.5±1.5	0.6
	CS11ZU2GA472MAGKA	Z5U	4700	± 20	13.5	7.0	7.5±1.5	0.6

Type : CS
T.C : SL, B, Z5U

Vertical kink short lead (lead style: N / bulk)

Table-4

Your part No	TDK part No.	T.C.	Cap. (pF)	C-Tol. (%)	Dimension (Unit : mm)			
					D Max.	T Max.	F	φd
	CS45SL2GA100JANKA	SL	10	± 5	7.0	7.0	7.5±1.5	0.6
	CS45SL2GA150JANKA	SL	15	± 5	7.0	7.0	7.5±1.5	0.6
	CS45SL2GA220JANKA	SL	22	± 5	7.0	7.0	7.5±1.5	0.6
	CS45SL2GA330JANKA	SL	33	± 5	7.0	7.0	7.5±1.5	0.6
	CS45SL2GA470JANKA	SL	47	± 5	8.0	7.0	7.5±1.5	0.6
	CS45SL2GA680JANKA	SL	68	± 5	9.0	7.0	7.5±1.5	0.6
	CS65-B2GA101KANKA	B	100	± 10	7.0	7.0	7.5±1.5	0.6
	CS65-B2GA151KANKA	B	150	± 10	7.0	7.0	7.5±1.5	0.6
	CS65-B2GA221KANKA	B	220	± 10	7.0	7.0	7.5±1.5	0.6
	CS70-B2GA331KANKA	B	330	± 10	7.5	7.0	7.5±1.5	0.6
	CS75-B2GA471KANKA	B	470	± 10	9.0	7.0	7.5±1.5	0.6
	CS85-B2GA681KANKA	B	680	± 20	9.5	7.0	7.5±1.5	0.6
	CS65ZU2GA102MANKA	Z5U	1000	± 20	7.0	7.0	7.5±1.5	0.6
	CS75ZU2GA152MANKA	Z5U	1500	± 20	8.0	7.0	7.5±1.5	0.6
	CS80ZU2GA222MANKA	Z5U	2200	± 20	9.5	7.0	7.5±1.5	0.6
	CS95ZU2GA332MANKA	Z5U	3300	± 20	12.0	7.0	7.5±1.5	0.6
	CS11ZU2GA472MANKA	Z5U	4700	± 20	13.5	7.0	7.5±1.5	0.6

Type : CS
T.C : SL, B, Z5U

Vertical kink long lead (lead style: V / Taping)

Table-5

Your part No	TDK part No.	T.C.	Cap. (pF)	C-Tol. (%)	Dimension (Unit : mm)			
					D Max.	T Max.	F	φd
	CS45SL2GA100JAVKA	SL	10	± 5	7.0	7.0	7.5±0.8	0.6
	CS45SL2GA150JAVKA	SL	15	± 5	7.0	7.0	7.5±0.8	0.6
	CS45SL2GA220JAVKA	SL	22	± 5	7.0	7.0	7.5±0.8	0.6
	CS45SL2GA330JAVKA	SL	33	± 5	7.0	7.0	7.5±0.8	0.6
	CS45SL2GA470JAVKA	SL	47	± 5	8.0	7.0	7.5±0.8	0.6
	CS45SL2GA680JAVKA	SL	68	± 5	9.0	7.0	7.5±0.8	0.6
	CS65-B2GA101KAVKA	B	100	± 10	7.0	7.0	7.5±0.8	0.6
	CS65-B2GA151KAVKA	B	150	± 10	7.0	7.0	7.5±0.8	0.6
	CS65-B2GA221KAVKA	B	220	± 10	7.0	7.0	7.5±0.8	0.6
	CS70-B2GA331KAVKA	B	330	± 10	7.5	7.0	7.5±0.8	0.6
	CS75-B2GA471KAVKA	B	470	± 10	9.0	7.0	7.5±0.8	0.6
	CS85-B2GA681KAVKA	B	680	± 20	9.5	7.0	7.5±0.8	0.6
	CS65ZU2GA102MAVKA	Z5U	1000	± 20	7.0	7.0	7.5±0.8	0.6
	CS75ZU2GA152MAVKA	Z5U	1500	± 20	8.0	7.0	7.5±0.8	0.6
	CS80ZU2GA222MAVKA	Z5U	2200	± 20	9.5	7.0	7.5±0.8	0.6
	CS95ZU2GA332MAVKA	Z5U	3300	± 20	12.0	7.0	7.5±0.8	0.6
	CS11ZU2GA472MAVKA	Z5U	4700	± 20	13.5	7.0	7.5±0.8	0.6

Flow soldering recommended condition

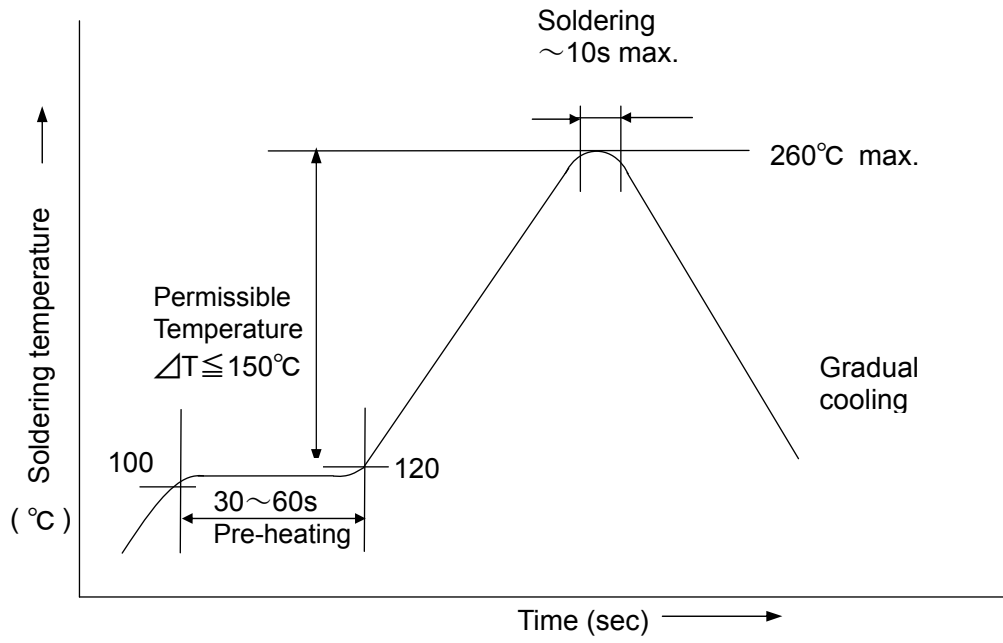

Fig-1